

DUAL OPERATIONAL AMPLIFIER

DESCRIPTION

The HG4580 is the dual operational amplifier, specially designed for improving the tone control, which is most suitable for the audio application.

Featuring noiseless, higher gain bandwidth, high output current and low distortion ratio, and it is most suitable not only for acoustic electronic parts of audio pre-amp and active filter, but also for the industrial measurement tools. It is also suitable for the head phone amp at higher output current, and further more, it can be applied for the handy type set operational amplifier of general purpose in application of low voltage single supply type which is properly biased of the input low voltage source.

FEATURES

- *Operating Voltage ($\pm 2V$ to $\pm 18V$)
- *Low Input Noise Voltage ($0.8 \mu V_{rms}$ typ.)
- *Wide Gain Bandwidth Product ($15MHz$ typ.)
- *Low Distortion (0.0005% typ.)
- *Slew Rate ($5V/\mu s$ typ.)
- *Bipolar Technology

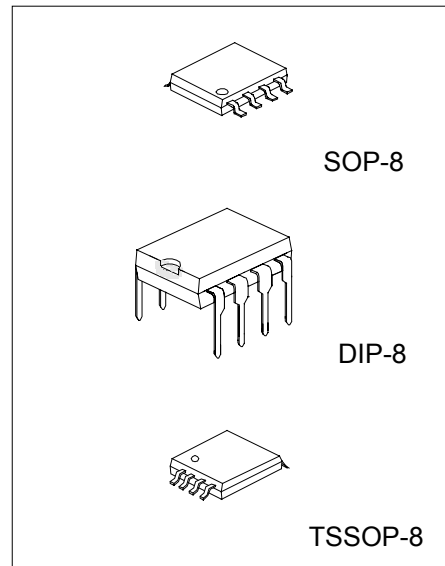

PIN CONFIGURATION

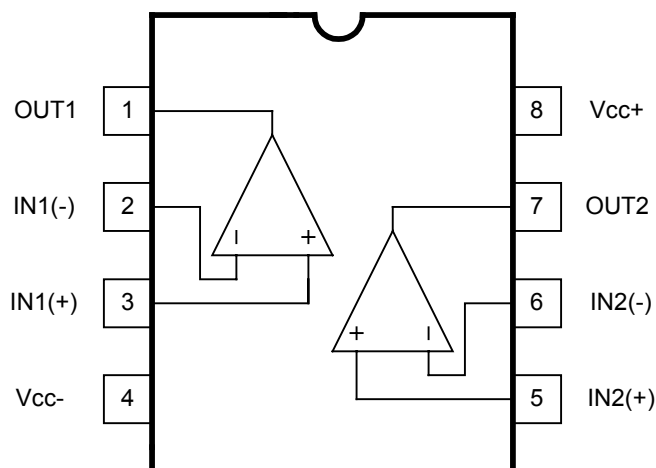

TEST CIRCUIT

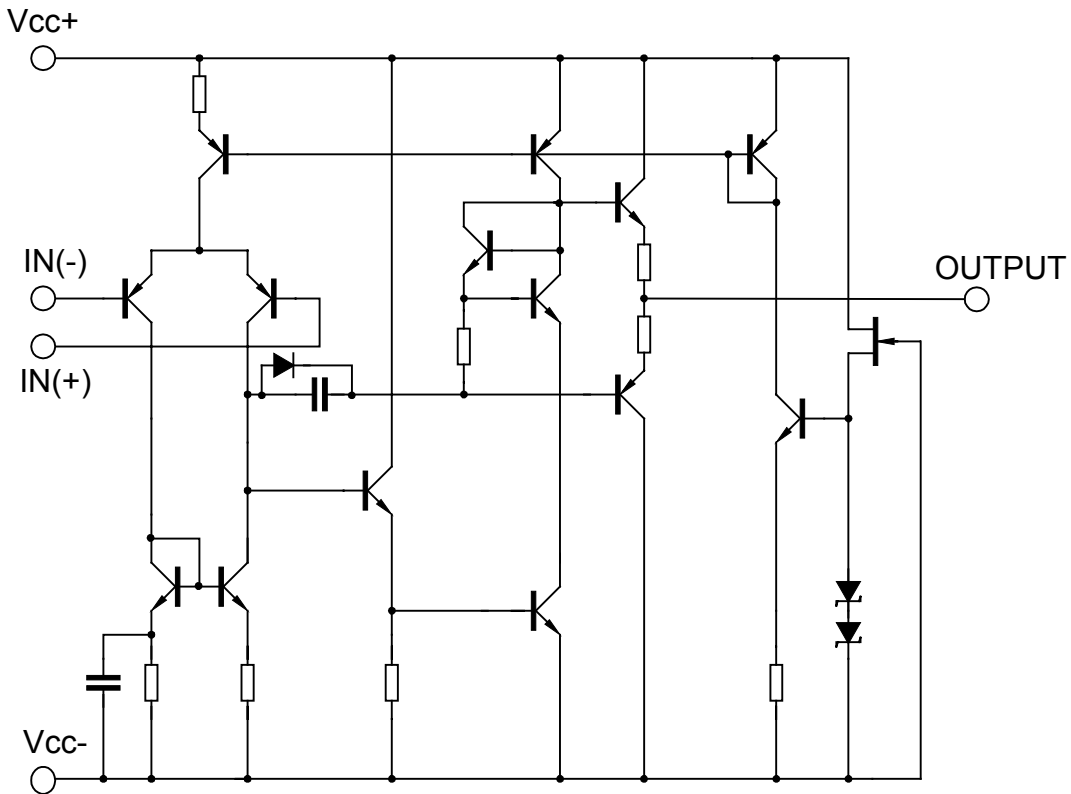

ABSOLUTE MAXIMUM RATINGS (Ta=25°C)

PARAMETER	SYMBOL	RATINGS	UNIT
Supply Voltage	V^+V^-	± 18	V
Input Voltage	V_{IC}	± 15	V
Differential Input Voltage	V_{ID}	± 30	V
Output Current	I_o	± 50	mA
Power Dissipation	P_d	300 (SOP-8) 800 (DIP-8) 250(TSSOP-8)	mW
Operating Temperature Range	T_{opr}	-40 to +85	°C
Storage Temperature Range	T_{stg}	-40 to +125	°C

ELECTRICAL CHARACTERISTICS ($V^+/V^- = \pm 15V$, $T_a = 25^\circ C$)

PARAMETER	SYMBOL	TEST CONDITION	MIN	TYP	MAX	UNIT
Input Offset Voltage	V_{IO}	$R_S \leq 10k\Omega$	-	0.5	3	mV
Input Offset Current	I_{IO}		-	5	200	nA
Input Bias Current	I_B		-	100	500	nA
Large Signal Voltage Gain	A_V	$V_o = \pm 10V$, $R_L \geq 2k\Omega$	90	110	-	dB
Output Voltage Swing	V_{OM}	$R_L >= 2k\Omega$	± 12	± 13.5	-	V
Input Common Mode Voltage Range	V_{ICM}		± 12	± 13.5	-	V
Common Mode Rejection Ratio	CMR	$R_S \leq 10k\Omega$	80	110	-	dB
Supply Voltage Rejection Ratio	SVR	$R_S \leq 10k\Omega$	80	110	-	dB
Operating Current	I_{CC}		-	6	9	mA
Slew Rate	SR	$R_L \geq 2k\Omega$	-	5	-	V/ μs
Gain bandwidth Product	GB	$f = 10KHz$	-	15	-	MHz
Total Harmonic Distortion	THD	$A_v = 20dB$, $V_o = 5V$, $R_L = 2k\Omega$, $f = 1KHz$	-	0.0005	-	%
Input Noise Voltage	V_{NI}	RIAA $R_s = 2.2 k\Omega$, 30kHzLPF	-	0.8	-	μV_{rms}

TYPICAL CHARACTERISTICS

Maximum Output Voltage Swing vs. Load Resistance

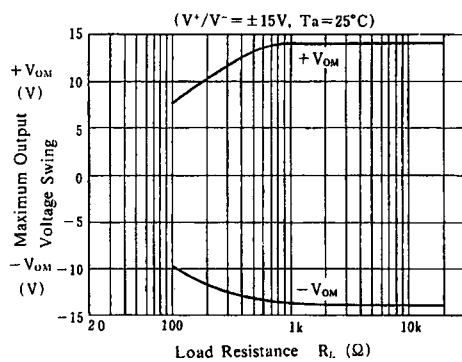

Maximum Output Voltage Swing vs. Frequency

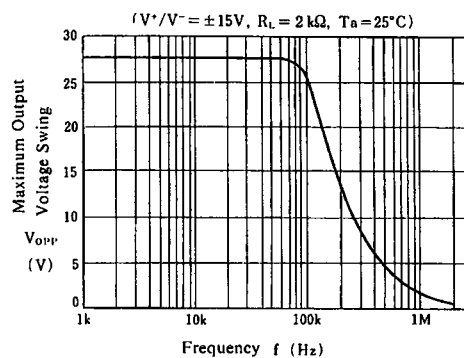

Output Voltage Swing vs. Output Current

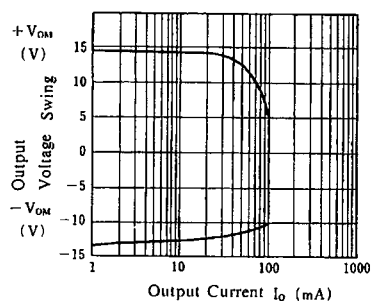

Equivalent Input Noise Voltage vs. Frequency

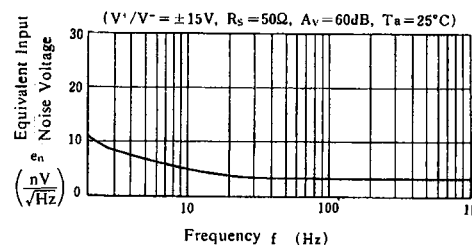

Operating Current vs. Temperature

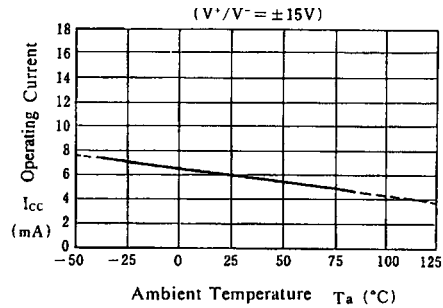

Output Voltage Swing vs. Temperature

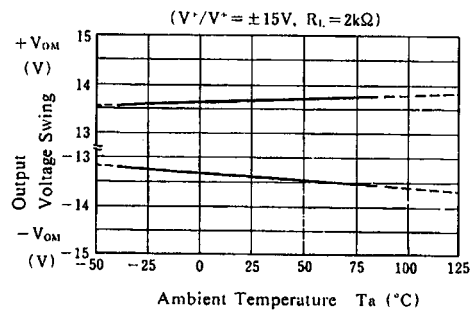

Input Offset Voltage vs. Temperature

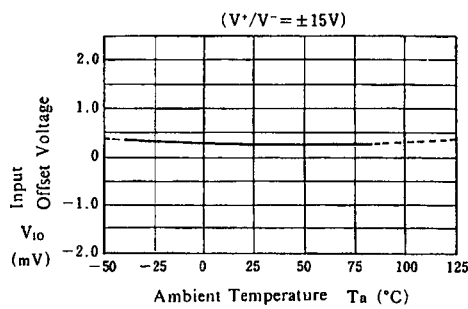

Input Bias Current vs. Temperature

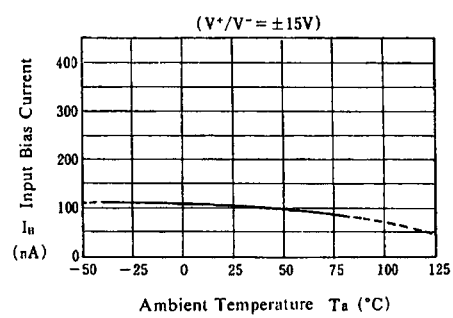

Maximum Output Voltage Swing vs. Operating Voltage

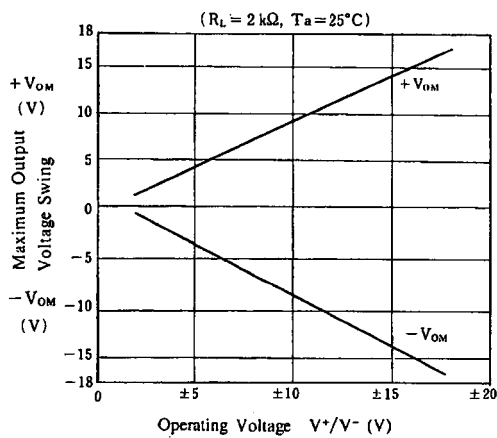

Operating Current vs. Operating Voltage

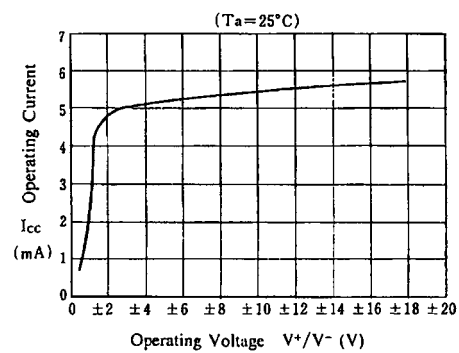

Total Harmonic Distortion vs. Output Voltage

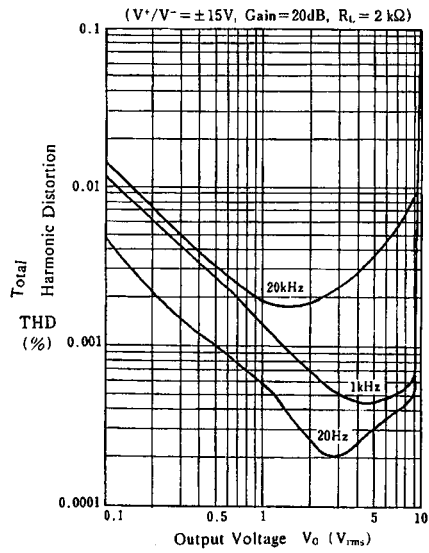

Voltage Gain, Phase vs. Frequency

